



Charcoal BBQ

Instruction manual



EN	Charcoal BBQ	2	DE	Holzkohlegrill	20
	<u>Instruction manual</u>			<u>Bedienungsanleitung</u>	
NL	Houtskool BBQ	8	IT	Barbecue a carbone	26
	<u>Gebbruikshandleiding</u>			<u>Manuale di istruzioni</u>	
FR	Barbecue à charbon de bois	14	ES	Barbacoa de carbó	32
	<u>Mode d'emploi</u>			<u>Manual de instrucciones</u>	

Model • Model • Modèle • Modell • Modello • Modelo:
FT690

Safety Instructions

- Read all instructions before use and retain for future reference.
- **Warning! Keep children and pets away from the BBQ at all times.** Do not allow children to operate it.
- **Warning! This barbecue will become very hot.** Do not move during operation or immediately after use before it completely cools down.
- Do not use indoors!
- Do not use the barbecue in a confined and/or habitable space, e.g. houses, tents, caravans, motor homes, boats or recreational vehicles. **Danger of carbon monoxide poisoning fatality.**

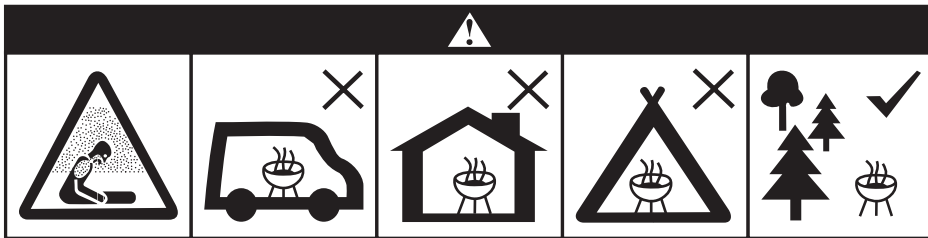

- **Warning! Do not use spirit or petrol for lighting or re-lighting!** Use only fire lighters complying to EN1860-3!
- Never use any volatile to start the charcoal as it is dangerous and can add unwanted flavour to your food. Electric start-up is recommended.
- **Warning:** Use caution when cooking as the appliance surfaces get hot. To avoid burns, always use protective gloves when in use. Do not wear loose clothing near the appliance.
- Only operate the appliance on a hard, level surface capable of supporting its weight when fully loaded.

- Never operate on wooden surface, wood deck or the like under any conditions.
- Use purpose designed barbecue tools with long, heat resistant handles.
- Do not cover the appliance before it completely cools down.
- Do not leave the appliance unattended during use.
- Do not modify the appliance in any way. Any modification of the appliance, misuse, or failure to follow the instructions may be dangerous and will invalidate your warranty.
- Never use accessories which are not recommended by the manufacturer. Only use original parts and accessories.
- Do not use this appliance near flammable materials (Petroleum based products, thinners or any other solid object that carries a flammable warning label).
- Do not store or use gasoline or Methylated Fuels or any other flammable vapours and liquids in the vicinity of this appliance.
- Do not store any gas cylinder in the vicinity of this appliance.
- The appliance must not have any overhead obstruction, e.g. trees, shrubs, lean-to roofs. Ensure a clearance of at least 1m around the appliance for ample ventilation.
- Do not use to heat any sealed glass/container with food. Pressure may build up and cause the container to burst, possibly resulting in personal injury or damage to the appliance.
- Clean the appliance after use.

Introduction

- Please take a few minutes to carefully read through this manual. Correct maintenance and operation of this appliance will provide the best possible performance from your BUFFALO product.
- BUFFALO prides itself on quality and service, ensuring that at the time of unpacking the contents are supplied fully functional and free of damage.
- Should you find any damage as a result of transit, please contact your BUFFALO dealer immediately.

Operation

- Remove the cooking grids.
- Place a small quantity charcoal into the charcoal pan.



For best results, we recommend using natural lump charcoal made from hardwood. Compared to briquettes, natural charcoals start faster, burn cleaner and longer, reach higher temperatures and produce less ash. Left-over natural charcoal also relights for re-use but ensure to knock off excess ash from the charcoal first.

1. Light charcoal with an electric starter or approved BBQ starters.



Do not use lighter fluids. Liquid chemicals are a fire hazard and will impact an undesirable taste to food.

2. Let the charcoal burn until red on the surface.
3. Now add more charcoal. Maximum charcoal quantity: 1.8kg. Ensure the charcoal does not exceed half the height between the cooking grid and the bottom of the charcoal pan.
4. Re-locate the cooking grids and wait for at least 30 minutes before first time cooking.



Do not cook before the charcoal has a coating of ash.

5. Lay food on the grids to start cooking.

Tips on food safety and grilling

- Thoroughly defrost frozen meat and poultry in the refrigerator before cooking. Keep raw meat and poultry away from cooked food.
- Always wash hands after handling raw meat and poultry, and before handling any ready-to-eat food.
- Wipe and disinfect surfaces that have been in contact with raw meat and poultry.
- When barbecuing meat and poultry, make sure the barbecue is really hot. Place the larger, thicker portions furthest away from the most intense heat to ensure thorough cooking without burning and turning frequently.
- Use separate utensils for handling raw meat/poultry and cooked food on the barbecue, or wash them thoroughly between uses.
- To check whether meat, particularly poultry is cooked thoroughly, pierce the flesh with a skewer or fork; the juices should run clear.

Cleaning, care & maintenance

- **Regularly clean your barbecue between uses, especially after extended periods of storage.**
- **Ensure the barbecue and its components are sufficiently cool before cleaning, care & maintenance, and storage. Never clean the barbecue surfaces with water while still hot.**

- To extend the life and maintain the condition of your barbecue, we strongly recommend that the unit be covered when left outside for any length of time, especially during the winter months.
- Inspect the barbecue on a regular basis as damp or condensation can form which may result in damage to the appliance. It may be necessary to dry the barbecue internally. It is possible for mould to grow on any fat-gathering parts. This should be cleaned off with hot soapy water.

Cleaning cooking grids and charcoal pans

- The cooking grids and charcoal pans can be cleaned using barbecue fluid. Avoid using wire wool and hard brushes as these may scratch the surface.
- Regularly remove excess grease or fat using a cloth dampened with hot soapy water. Dry thoroughly.
- Excess fat and food debris can be removed from inside the body using a soft brush.
- Let dry thoroughly.

Removing ash

- Routinely remove ash from the charcoal pans.
- Remove the cooking grids then remove the ash directly.
- Dispose of cooled ash by placing them in aluminium foil, soaking with water and discarding in a non-combustible container.

Troubleshooting

Fault	Probable Cause	Solution
Flare-up	Grease buildup	Remove grease from inside the body using a soft brush
	Excessive fat in meat	Trim fat from meat before grilling

Technical specifications

Note: Due to our continuing program of research and development, the specifications herein may be subject to change without notice.

Model	Product Dimensions (h x w x d mm)	Weight
FT690	900 x 1000 x 320	14.9kg

Compliance

BUFFALO parts have undergone strict product testing in order to comply with regulatory standards and specifications set by international, independent, and federal authorities.

All rights reserved. No part of these instructions may be produced or transmitted in any form or by any means, electronic, mechanical, photocopying, recording or otherwise, without the prior written permission of BUFFALO. Every effort is made to ensure all details are correct at the time of going to press, however, BUFFALO reserve the right to change specifications without notice.

Installation

- This appliance is for outdoor use only and should be placed in a well-ventilated area.
- The sides of the barbecue should **NEVER** be closer than 1 metre from any combustible surface, including trees and fences and make sure that there are no heat sources nearby (cigarettes, open flames, spark, etc.). Keep away from any flammable materials!

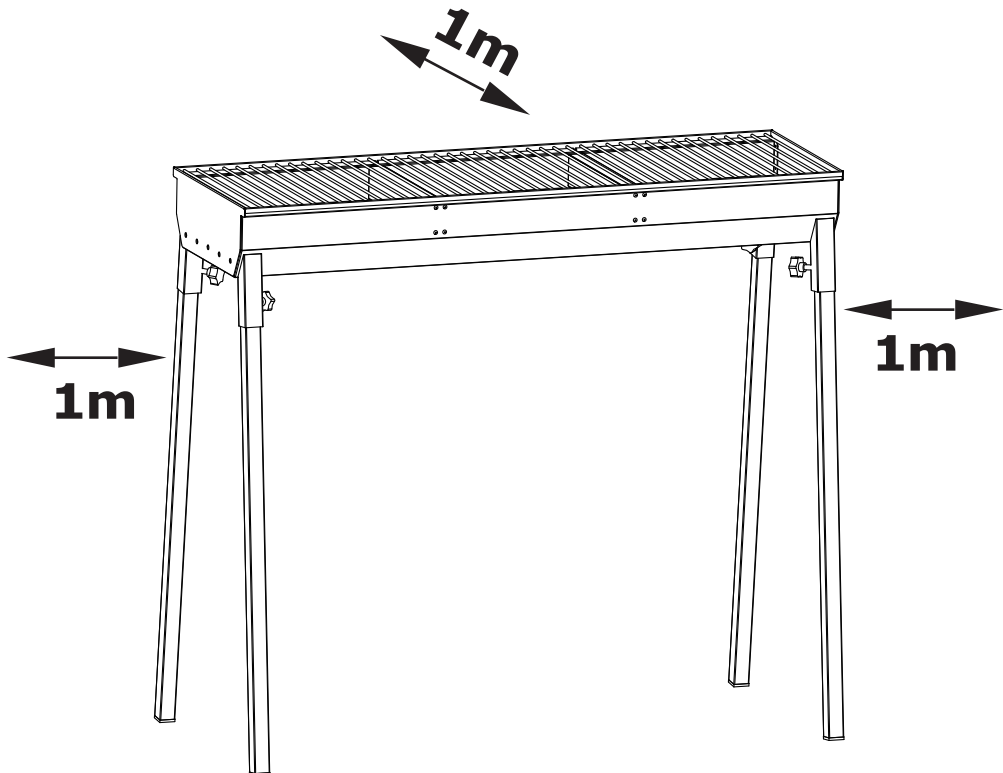

IMPORTANT! Whilst every care is taken in the manufacture of this product, care must be taken during assembly in case sharp edges are present.

Assembly instructions

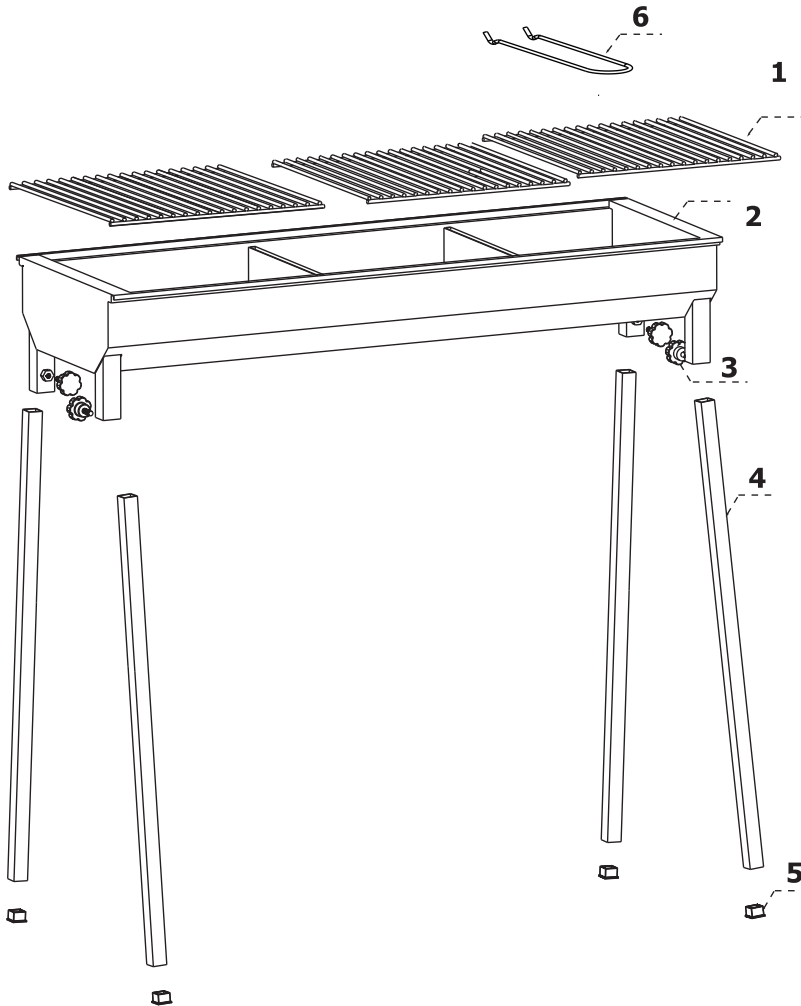

1.	Cooking grid (x3)	4.	Leg (x4)
2.	Main body	5.	Leg's cap (x4)
3.	Screw fixing set (x4)	6.	Grid handle (x1)



Note:

- Assemble the product as illustrated above.
- Specifications are subject to change without prior notice.