

First of all, thank you for choosing Ott products, we will be excellent products and excellent service Thank you for your support andove.

The factory mainly produces Western Kitchen Equipment, and its supporting products are: Series Griddle, Fryer Series, HWC series, fries holding cabinets, snack products.

Power use, please read these instructions carefully to ensure proper use.

### 一、 Warning:

1, The product must be securely grounded before use!

2, Cleaning may not be used directly to clean water pipes!

OT desktop chips cabinet series is absorbing advantages of similar products at home and abroad the design is made with new models

Ying, reasonable structure, easy operation, fast heating, temperature uniformity, energy-saving features, suitable for shopping malls, supermarkets, convenience stores and other high traffic and other places.

### 二、 First, the basic technical parameters:

Item No	Frequency	Voltage	Power	Dimensions
HCW-833	50Hz	220V	0.75kW	1000*700*1580mm

### 三、 Second, transport and storage:

In the transport process, the product should be handled with care to prevent severe vibration, packaged products are generally not long-term open storage should be placed in well-ventilated, non-corrosive gas warehouse. Not upside down, need for temporary storage, should be water-resistant measures.

Third, installation considerations and the use of the environment:

1, The product should be placed on a stable, non-combustible material about 10cm above the left side of the back should be from non-combustible material (such as brick walls, etc.) 20cm or more.

2, The device uses the supply voltage must match the nameplate of the supply voltage.

3, The user need for the equipment installed near the power switch, fuses and leakage protection, switching not allowed to put their things in front for easy operation.

4, The device must be securely grounded before use!

5, The start of electrical component products should be checked before the connection is solid, safe ground is reliable.

6, The replacement power cords should use the same type cables, and asked professionals to be replaced.

7, The electrical connection of the product installation and maintenance, operating permit holders should be invited to be installed.

### 四、 Fourth, methods of operation:

1,To take place in the French fries basin oil basin, the power, turn on the switch for heat insulation.

2, The french fries fried chips placed in the basin, after infrared heating, the chips at a certain temperature in constant, taken to an insulating effect.

3, The use of the process, abnormal situation must immediately stop using, troubleshooting by checking, before continued use.

## 五、 Cleaning and maintenance:

- 1, In the cleaning and maintenance should be cut off the power to prevent accidents.
- 2, The day after the work is non-corrosive cleaning agents can be used wet towels, clean the surface of the furnace surface and the power pinout is strictly prohibited direct rinse with water! To avoid damage to electrical performance.
- 3, The cleaning process, the timely cleanup of the oil drip bowl to prevent overflow.

## 六、 Electrical schematics

### Seven random accessories:

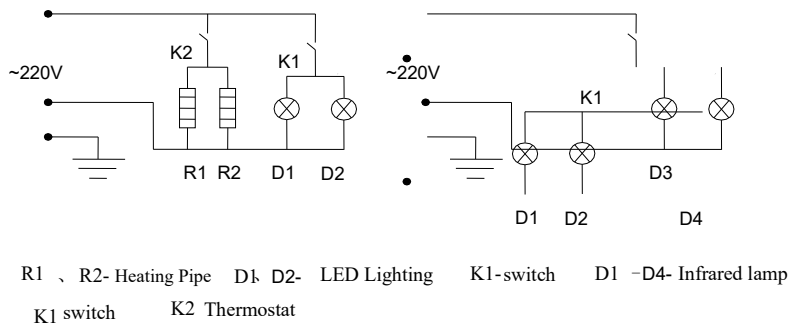

## A drip basin, side glass, a, a manual, certificate.

### 七、 Warranty: Product life-long maintenance

- 1, The product is valid for three guarantees: six months
- 2, Three bags of confirmation of validity:  
Warranty valid from the date of sale of notes, net of occupation because of repair, no parts for repairs delayed the final day of the period of leave days for the magic to the day following the holiday period of the last day of the three bags.
- 3, Is one of the following circumstances, do not implement three, the implementation of a reasonable repair charges:
  - a, More than three packs of validity;
  - b, Certificate and period instruments, but can prove that period, except in three bags;
  - c, Three bags of certificate does not match the content and physical goods or altered identity;
  - d, Failure to require the use of product specifications, maintenance, maintenance caused the damage;
  - e, Damage due to force majeure;
  - f, Maintenance replacement down all parts, components and accessories, all owned by the factory;
  - g, The factory for product failure, other than live except the warranty liability.(Specification change without notice)

# **Pedestal Fries Display**

## **Warmer**