



# MST110



## MST110 Mach MST110 Rack Conveyor Tunnel Dishwasher

High capacity commercial dishwasher and utensil washer with rack conveyor system for flight of baskets through the washing tunnel. With single wash and rinse phases, the MST110 is an ideal entry level tunnel dishwasher, ideal for busy restaurants, medium size hotels, food production and manufacturing plants looking to wash between 50-80 baskets per hour.

- ✓ Washes 55-80 racks per hour
- ✓ Fits Gastronorm Trays
- ✓ Highly Configurable
- ✓ Gravity Waste
- ✓ Digital temperature control
- ✓ 1100mm wash tunnel
- ✓ WRAS approved non-return valve
- ✓ 500 x 500mm Basket
- ✓ Bespoke tabling & roller systems
- ✓ Optional power assisted roller systems
- ✓ Optional drying & heat recovery units

## Specifications

Summary		Power and Performance	
<b>Brand</b>	Mach	<b>Power Type</b>	3 Phase
<b>Range</b>	Electronic	<b>Power Consumption (kW)</b>	19.1kW (Hot Fill) or 28.1kW (Cold Fill)
<b>Model Number(s)</b>	MST110	<b>Amps</b>	47.5A (Hot Fill) or 70A (Cold Fill)
<b>Unit Type</b>	Conveyor Tunnel Dishwasher	<b>Wash Tank</b>	58 Litres (9kW Heating)
<b>Basket Size (mm)</b>	500 x 500	<b>Rinse Boiler</b>	23 Litres 18kW (Hot fill) or 27kW (Cold Fill)

Key Specifications		Weight & Dimensions	
<b>Break Tank</b>	WRAS Non Return Valve	<b>Height (mm)</b>	1470
<b>Waste Type</b>	Gravity Waste	<b>Width (mm)</b>	1100
<b>Cycle Time (Seconds)</b>	180, 360	<b>Depth (mm)</b>	765
<b>Cycle Type</b>	Selectable	<b>Clear Entry Height (mm)</b>	420
<b>Key Features</b>	GN 1/1 Compatible, Rinse Booster, Heat Recovery, Auto Chemical Dosing System	<b>Weight (Kg)</b>	200

## Technical Diagram

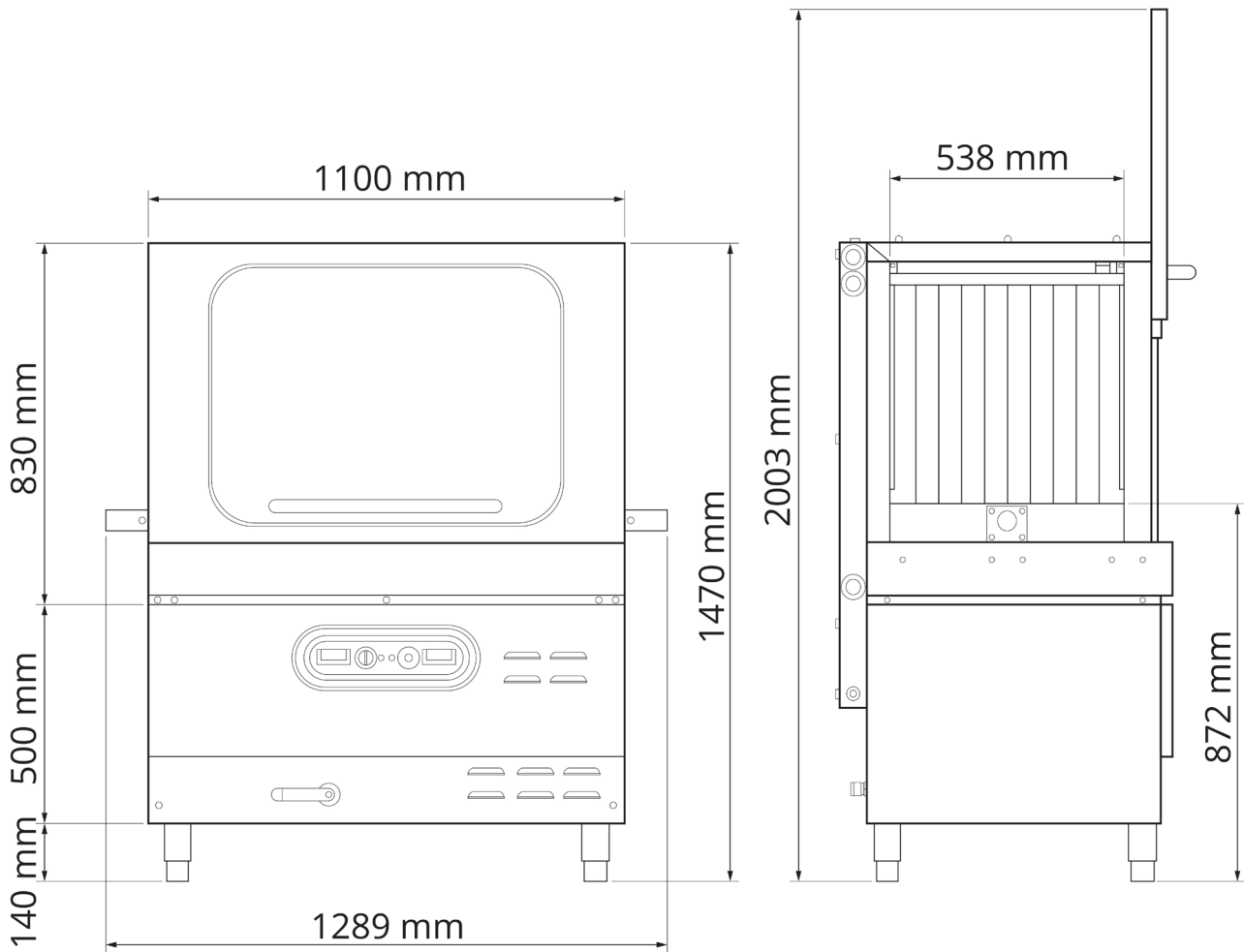

**Industrial Warewashers**  
Woodside Industrial Estate  
Dunmow Road  
Bishop's Stortford  
Hertfordshire  
CM23 5RG

### Customer Care

**Tel:** 01279 876500 (Option 3)

**Email:** sales@industrial-warewashers.com

### Opening Hours

Monday – Friday:  
8.30am – 5.30pm