



# VACUUM SEALER SE-310

Tabletop model. 10 m³/h. 320 mm



FOOD PRESERVATION AND SOUS-VIDE  
VACUUM PACKING MACHINES · SENSOR LINE



## SALES DESCRIPTION

320 mm sealing bar.  
10 m³/h Busch vacuum pump.  
Vacuum controlled by sensor.

- ✓ Powered by Busch.
- ✓ Vacuum controlled by sensor.
- ✓ Vacuum PLUS.
- ✓ Digital keyboard.
- ✓ Control panel equipped with display indicating the exact vacuum percentage.
- ✓ "Pause" button to marinate food.
- ✓ Safe liquid packing thanks to sensor control.
- ✓ Double seal.
- ✓ Cordless sealing bar.
- ✓ Bag-sealing programme.
- ✓ Pulse-controlled decompression.
- ✓ Vac-Norm ready with Automatic decompression.
- ✓ Stainless steel body and chamber. Deep-drawn chamber.
- ✓ Damped transparent lid of highly durable polycarbonate.
- ✓ Dry-oil programme for drying the pump.
- ✓ Working hours counter for oil changes.
- ✓ Safety system with protection against vacuum failure.
- ✓ NSF-listed model.

## INCLUDES

- ✓ Sensor controls
- ✓ Up to 10 seconds of extra vacuum pull
- ✓ Soft air function
- ✓ Dry oil cycle
- ✓ BUSCH pump
- ✓ NSF approved
- ✓ Clear methacrylate lid
- ✓ Filling plate

## OPTIONAL

- Vacuum packing bags accessories
- External vacuum kit for Vac-Norm, containers and
- Support for liquid packaging
- Additional filling plates

## ACCESSORIES

- Filling plates
- Liquid insert plates
- Vac-norm external vacuum kits
- Vac-norm containers
- Smooth bags for vacuum packing

## SPECIFICATIONS

Pump capacity: 10 m³/h  
 Pump capacity (60 Hz): 12 m³/h  
 Bar length: 320 mm  
 Total loading: 370 W  
 Vacuum pressure (maximum): 2 mbar

Plug: --

### Internal dimensions

- ✓ Width: 330 mm
- ✓ Depth: 360 mm
- ✓ Height: 155 mm

### External dimensions (WxDxH)

- ✓ Width: 384 mm
- ✓ Depth: 465 mm
- ✓ Height: 403 mm

Net weight: 39.5 kg

Noise level (1m.): 75 dB(A)  
 Background noise: 32 dB(A)

### Crated dimensions

460 x 530 x 460 mm  
 Gross weight: 46.5 kg

## AVAILABLE MODELS

1140628	SE-310 230/50-60/1
1140629	SE-310 120/50-60/1
1140640	SE-310 230/50-60/1 AUS

\* Ask for special versions availability





# VACUUM SEALER SE-310

Tabletop model. 10 m<sup>3</sup>/h. 320 mm



FOOD PRESERVATION AND SOUS-VIDE  
VACUUM PACKING MACHINES · SENSOR LINE

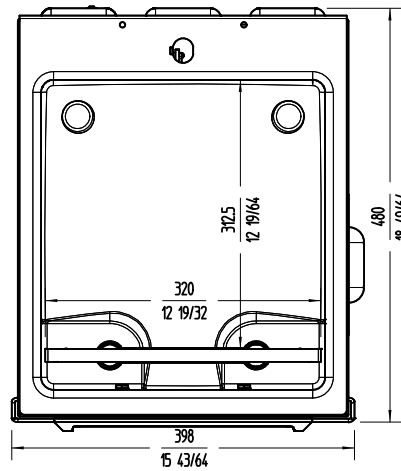
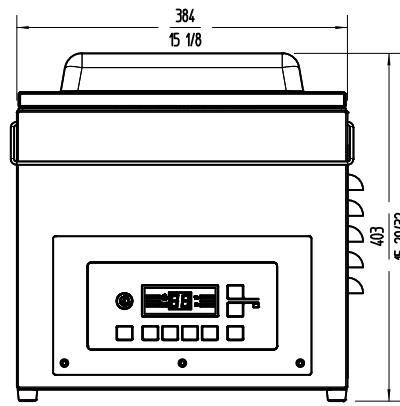
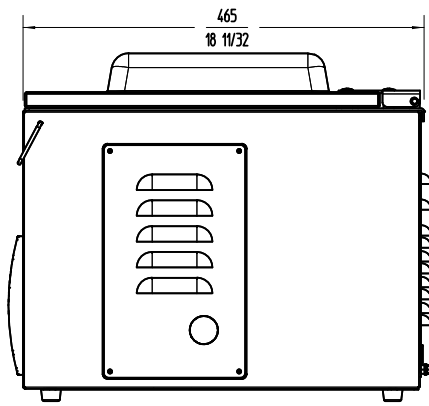

[www.sammic.co.uk](http://www.sammic.co.uk)

Food Service Equipment Manufacturer

Unit 2, Trevanah Road  
Troon Industrial Park  
LE4 9LS - Leicester

[uksales@sammic.com](mailto:uksales@sammic.com)  
Tel.: +44 0116 246 1900



Project

Date

Item

Qty

Approved

product sheet  
updated 20/11/2023